

Assembly Instructions for Enclosures type: ZEA231513 to ZEA624522 & ZMEA231513 to ZMEA624522

IMPORTANT: This document should be read carefully before commencing installation

Zones of Use for Terminal Box - as defined in IEC/EN 60079-0 and IEC/EN 60079-10-1/60079-10-2

- Group II Category 1G, for use in Zone 0 (plus Zone 1 and Zone 2).
- Group II Category 1D, for use in Zone 20 (plus Zone 21 and Zone 22).
- Group II Category 2G, for use in Zone 1 (plus Zone 2).
- Group II Category 2D, for use in Zone 21 (plus Zone 22).

Service Temperature: -60°C to +80°C

Minimum Installation Temperature: -5°C

Certification Details

Box Type: ZEA231513 to ZEA624522 & MEA231513 to ZMEA624522

⊕ II 2G Exeb IIC Gb, ⊕ II 2D Extb IIIC Db IP66

⊕ II 2G Exib IIC Gb, ⊕ II 2D Exib IIIC Db IP66

⊕ II 1G Exia IIC Ga, ⊕ II 1D Exia IIIC Da IP66

Baseefa08ATEX0207U / IECEx BAS08.0064U

EMC Ex TC RU C-GB.AA87.B.00430

Component Certified Enclosure Only

Additional certification required when assembled with other electrical equipment.

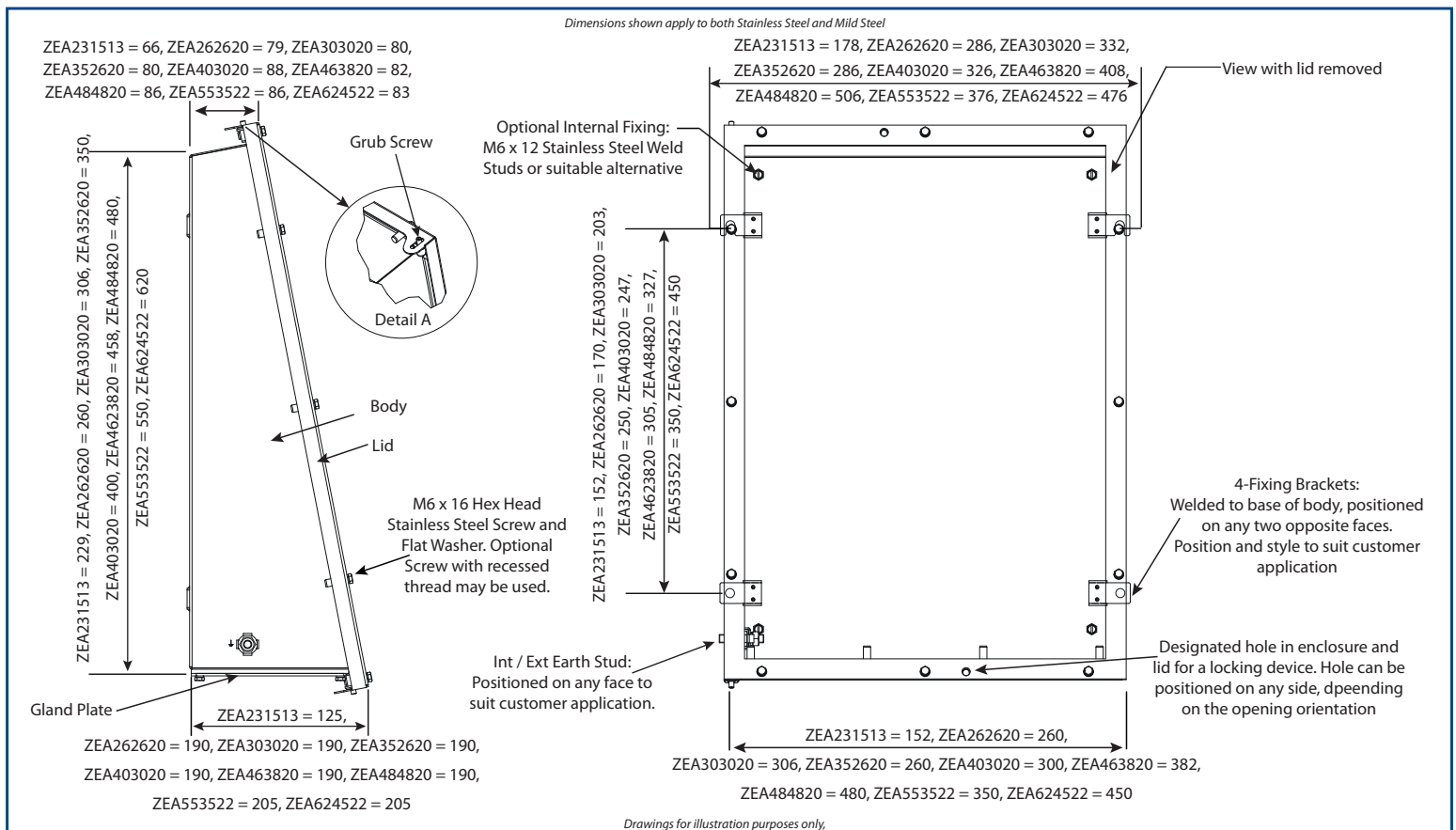

SCHEDULE OF LIMITATIONS:

- The enclosures shall not be exposed to temperatures outside the range of -60°C to +80°C.
- Unused entry holes shall be fitted with stopping plugs as specified in the description below. The operating temperature range of the enclosure is limited to that of the stopping plug fitted.
- Only breather / drain devices as specified in the description below may be used with these enclosures. The breather / drain devices must be installed in their correct orientation in the bottom face gland plate of the enclosure. The operating temperature range of the enclosure is limited to that of the breather / drain device fitted.
- Unused entries may be fitted with alternative stopping plugs and/or breather drains to those listed in the schedule. The user is responsible for ensuring that the protection concept temperature class and relevant IP rating are maintained.**
- The enclosure service temperature range is limited to -60°C to +80°C when the following optional items are used / fitted:
 Hawke M10 or M16 internal / external earth stud via a threaded bush.
 Hawke internal / external earth stud to 9464.
 EMC self-adhesive fine / braid mesh on gaskets.
 Nyloc label fixing method.

TO OPEN THE LID (with hinge):

1. Disconnect power (isolate all circuits).
2. Unlock padlock (if fitted) and remove.
3. Untighten the M6 lid securing screws.
4. Carefully swing the lid up / down on its hinges.

TO CLOSE THE LID (with hinge):

1. Carefully close the lid.
2. Tighten the M6 lid securing screws.

TO REMOVE THE LID (with hinge):

1. Disconnect power (isolate all circuits).
2. Unlock padlock (if fitted) and remove.
3. Untighten the M6 lid securing screws.
4. Screw one of the hinge grub screws inwards until it clears the hole in the lid.
5. Hold the lid securely and then screw the other grub screw inwards until it clears the hole in the lid.
6. Remove the lid and place in an area where it will not be subject to damage or moisture.

TO REPLACE THE LID (with hinge):

1. Ensure the inside of the lid is dry and free from dust and foreign matter.
2. Place the lid back onto the base and hold securely in position.
3. Unscrew the hinge grub screws through the holes in the lid as far as possible.
4. Tighten the M6 lid securing screws.

TO REMOVE THE LID (without hinge):

1. Disconnect power (isolate all circuits).
2. Unlock padlock (if fitted) and remove.
3. Untighten the M6 lid securing screws.
4. Remove the lid and place in an area where it will not be subject to damage or moisture.

TO REPLACE THE LID (without hinge):

1. Ensure the inside of the lid is dry and free from dust and foreign matter.
2. Place the lid back onto the base and hold securely in position.
3. Tighten the M6 lid securing screws.

ENCLOSURE INSTALLATION (EI)

- a) The IP rating of the enclosure must be maintained for the area of use (e.g. IP6* for Zone 21 dust environment) by the use of correct arrangement of cable/gland/sealing arrangements and in accordance with the installation codes as detailed in IEC/EN 60079-14 and these installation instructions.
- b) The enclosure may be ready supplied with cable entries. Where the customer drills cable entries they must be installed in accordance with the component certificates Baseefa 08ATEX0207U or IEC Ex BAS 08.0064U and enclosure limitations, these specify a maximum clearance on the entry thread of 0.7mm for plain holes and where adjacent cable entries are installed sufficient clearance must be maintained to allow for the fitting of sealing/retaining washers and the rotation of the cable gland hexagons, and leave a minimum of material between adjacent holes in line with the above certificate number(s).
- c) When a document pocket is fixed to the inside of the lid, care must be taken by installer / end-user to prevent static build-up i.e. plastic wallets must not be used to contain documents within the enclosure.

The enclosures may be fitted with the following certified stopping plugs, int/ext earth studs and breather drain devices:

Manufacturer	Product	Type	Certificate Number	IP Rating
Hawke	Stopping Plug	375	IECEx BAS 12.0065X / Baseefa12ATEX0095X Operating Temp. -60°C to +75°C	IP 66/67
Hawke	Stopping Plug	387	IECEx BAS 06.0029U / Baseefa06ATEX0118U Operating Temp: Nitrile O'Ring -60°C to +80°C Silicone O'Ring -60°C to +160°C	IP 66/67
Hawke	Stopping Plug	390	IECEx BAS 11.0079X / Baseefa11ATEX0157X Operating Temp: Nitrile O'Ring -60°C to +80°C Silicone O'Ring -60°C to +160°C	IP 66
Hawke	Internal/External Earth	IES 10 IES 6/12 ES 6/12	IEC Ex BAS090013U / Baseefa09ATEX0039U Operating Temp: -60°C to +200°C	IP 66
Hawke	Stopping Plug	487	IECEx BAS 11.0071X / Baseefa11ATEX0149X Operating Temp: Nitrile O'Ring -60°C to +80°C Silicone O'Ring -60°C to +160°C	IP 66/67
Hawke	Breather Drain	389	IECEx BAS 11.0075X / Baseefa11ATEX0153X Operating Temp: Nitrile O'Ring -60°C to +80°C Silicone O'Ring -60°C to +160°C	IP 66
Hawke	Breather Drain	385	IECEx BAS 11.0075X / Baseefa11ATEX0153X Operating Temp: -60°C to +80°C	IP 66

EXTERNAL EFFECTS AND AGGRESSIVE SUBSTANCES:

The end user shall take into consideration for health and safety regulations when changing environmental conditions and in the presence of extraneous voltages, humidity, vibrations, contamination and other external effects, take into account the limits of the operating conditions established by Hawke International.

Equipment parts used must be appropriate to the intended mechanical and thermal stresses and capable of withstanding attack by existing or foreseeable aggressive substances.

EARTHING:

- a) Where there is a requirement for bonding of gland plate, this can be achieved by using earthtags on the outside of the enclosure in conjunction with cable glands or by use of gland plates and enclosure lids with factory fitted earth studs. In the case of painted boxes, consideration must be given to the removal of the paint. e.g. under a serrated washer on the inside of the box which may lead to corrosion of the enclosure and potential reduction in earthing protection. This area following installation must be protected against corrosion.

Note : *There is an integral connection from the internal earth connection through to the external of the box.*

EU Attestation of Conformity in accordance with European Directive 2014/34/EU**Manufacturer: Hawke International****Address: Oxford Street West, Ashton-under-Lyne, OL7 0NA, United Kingdom****Equipment: ZEA Stainless Steel & ZMEA Mild Steel Range of Enclosures****Provisions of the Directive fulfilled by the Equipment:**

Group II Category 2G Exeb IIC T* Gb, II 2D Extb IIIC T***C Db - IP66

Group II Category 2G Exib IIC T* Gb, II 2D Exib IIIC T***C Db IP66

Group II Category 1G Exia IIC T* Ga, II 1D Exia IIIC T***C Da IP66

Notified Body for EU-Type Examination: Baseefa 1180 Buxton UK**EU-type Examination Certificate:** Baseefa08ATEX0207U**Notified Body for production:** SGS-Baseefa 1180 Buxton UK**Harmonized Standards used:** EN IEC60079-0: 2018, EN60079-7: 2015, EN60079-11: 2012, EN60079-31: 2014

On behalf of the above named company, I declare that, on the date the equipment accompanied by this declaration is placed on the market, the equipment conforms with all technical and regulatory requirements of the above listed directives.

.....

A. Tindall
Technical Manager